



# HYDRAULIC BOTTLE JACK

CAPACITY : 2 TO 500 TONNES.  
PLAIN RAM AND THREADED RAM

ESTABLISHED 1960  
AN ISO 9001 : 2000 COMPANY

## STANDARD



- RELIABLE.
- SOLID.
- COMPACT.
- LIGHT WEIGHT AND LOW HANDLE EFFORTS MAKE WORK LOT EASIER.
- SIMPLE DESIGN.
- **THREADED RAM WITH SAFETY LOCK NUT FOR UNLIMITED DURATION LOAD HOLDING ADVANTAGES.**
- ALL CRITICAL COMPONENTS MADE FROM SELECTED ALLOY STEEL AND ELECTRICALLY WELDED FOR GREATER STRENGTH AND SAFETY.

## CUSTOM MADE



- FAST EASY MAINTENANCE
- SPARES AND SERVICES COUNTRY WIDE
- VERSATILE PERFORMANCE.
- WIDEST SELECTION OF STANDARD CAPACITIES.
- RELIABILITY THROUGH PROVED AND ACCEPTED HIGHEST STANDARD OF QUALITY PRODUCT PERFORMANCE.
- EACH PRODUCT GOES THROUGH A SERIES OF CHECKS AND TESTS TO CONFORM TO BIS AND INTERNATIONAL STANDARDS.



**USE " SUPER HYDRAULIC POWER" VANKOS JACKS FOR SAFE AND EASY LIFTING OF EARTH MOVING VEHICLES FOR MAINTENANCE**  
PLEASE PROVIDE MAXIMUM DETAILS OF YOUR APPLICATION TO OFFER YOU A BEST POSSIBLE SOLUTION.

- THE MOST INNOVATIVE ENGINEERING STAFF AND HIGHLY SKILLED EXPERIENCED WORK FORCE IN THE COUNTRY WITH SPARES AND SERVICES COUNTRY WIDE.
- VANKOS CAN PROVIDE SOLUTIONS TO THE SPECIAL REQUIREMENTS OF CUSTOMERS. SOME VANKOS JACKS ARE AVAILABLE IN SPECIAL CONFIGURATION NOT LISTED IN THIS CATALOG. GIVE US YOU SPECIFICATION AND WE SHALL DESIGN A JACK FOR YOU.

**PLEASE ASK FOR DETAILS AND CATALOGS.**

HYDRAULIC POWER FOR ALL APPLICATIONS



LIFT



PRESS



PUSH



PULL



BEND



# Technical Specifications-VANKOS Hydraulic Jacks-Standard Series-PLAIN RAM-Type : SS

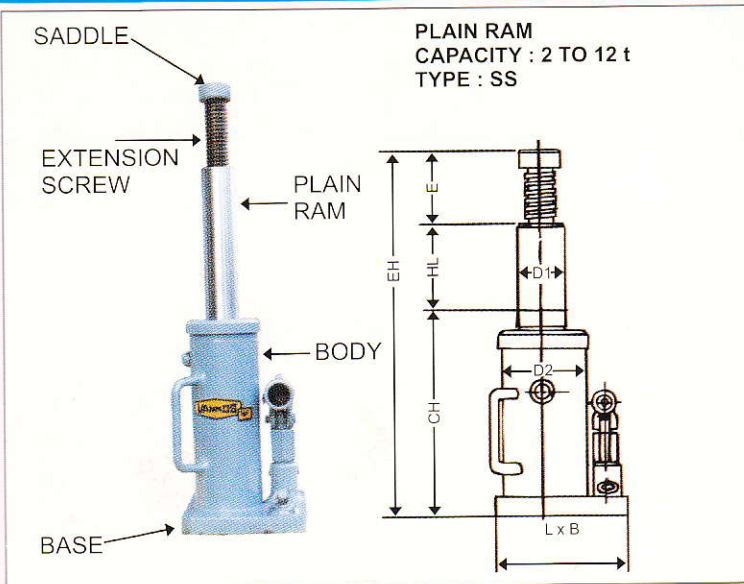

TYPE	SS 2/120	SS 3/150	SS 5/150	SS 8/150	SS 10/150	SS 12/150	SS 15/150	SS 20/150
Capacity In Tonnes	2	3	5	8	10	12	15	20
Closed Ht CH	190	220	231	235	235	235	250	250
Hyd. Lift HL	120	150	150	150	150	150	150	150
Extn. Screw E	75	80	100	100	100	100	100	100
Extd. Ht.EH	385	450	481	486	486	486	500	500
Ram Dia D1	30	30	36	43	46	52	58	65
Body Dia D2	65	65	72	86	90	98	110	124
Base Size L x B	115 x 115	115 x 115	125 x 125	150 x 140	150 x 150	150 x 150	170 x 170	180 x 180
Appx. Weight in kg	5	6	8	10	11	12	16.5	22

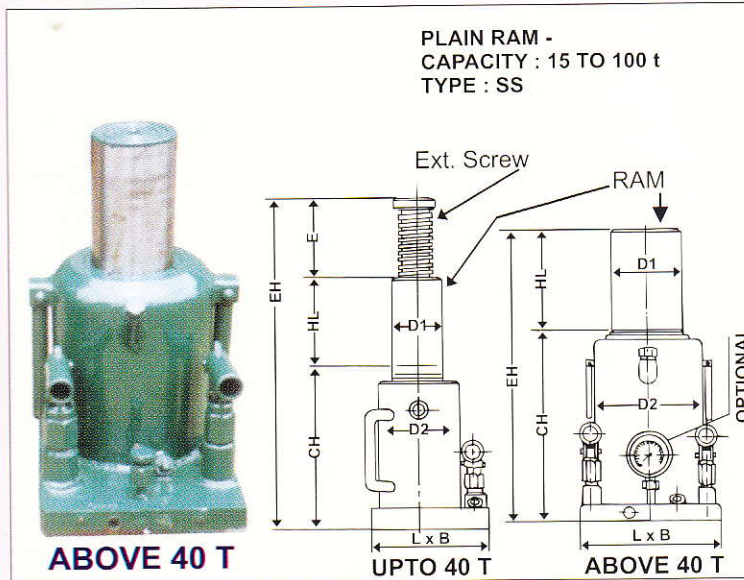

TYPE	SS 25/150	SS 30/150	SS 35/150	SS 40/150	SS 50/150	SS 75/150	SS 100/150
Capacity In Tonnes	25	30	35	40	50	75	100
Closed Ht CH	270	270	280	287	275	275	300
Hyd. Lift HL	150	150	150	150	150	150	150
Extn. Screw E	100	100	100	100	X	X	X
Extd. Ht.EH	520	520	530	537	425	425	450
Ram Dia D1	70	76	80	90	100	110	127
Body Dia D2	136	144	159	178	198	213	233
Base Size L x B	190 x 190	200 x 200	215 x 200	250 x 225	240 x 300	255 x 315	280 x 330
Appx. Weight in kg	26	29	32	36	56	75	90

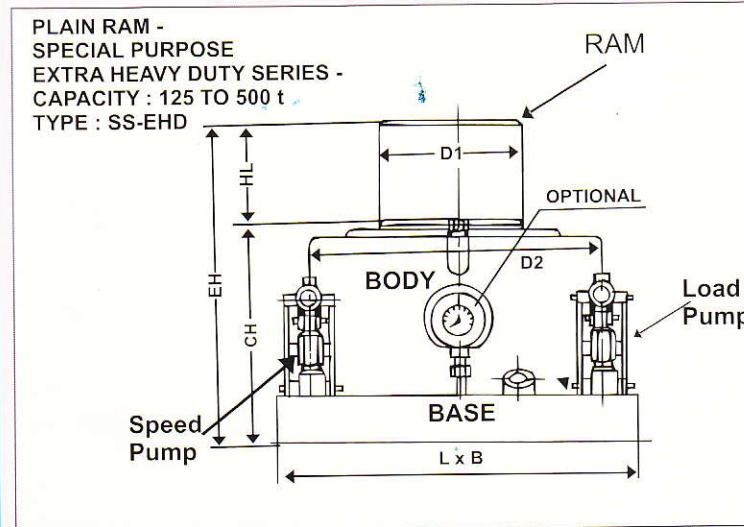

TYPE	SS-EHD 125/150	SS-EHD 150/150	SS-EHD 200/150	SS-EHD 250/150	SS-EHD 300/150	SS-EHD 400/150	SS-EHD 500/150
Capacity In Tonnes	125	150	200	250	300	400	500
Closed Ht CH	300	300	335	335	335	380	415
Hyd. Lift HL	150	150	150	150	150	150	150
Extd. Ht.EH	450	450	485	485	485	530	565
Ram Dia D1	145	155	175	200	210	275	315
Body Dia D2	298	333	358	383	423	523	623
Base Size L x B	380 x 350	420 x 380	450 x 400	500 x 440	520 x 475	675 x 550	820 x 675
Appx. Weight in kg	120	175	245	335	395	617	842

1. Only Load (Pressure) Pump is provided upto 40t. Jacks and both Load and Speed Pumps are provided from 50t. onward Jacks both with Plain Ram and Screwed Ram.
2. Extension Screw is provided upto 40t. Jacks with Plain Ram only.
3. Pressure Gauges are optional. However Pressure Gauge connection is provided with 50T. onward Jacks both with Plain Ram and Threaded Ram.
4. Saddle is provided upto 40T. Jacks with Plain Ram only. But saddle is provided from 2t. to 500t Jacks in Threaded Ram type.

# Technical Specifications-VANKOS Hydraulic Jacks Standard Series **THREADED RAM** With Safety Lock Nut-Type : SR

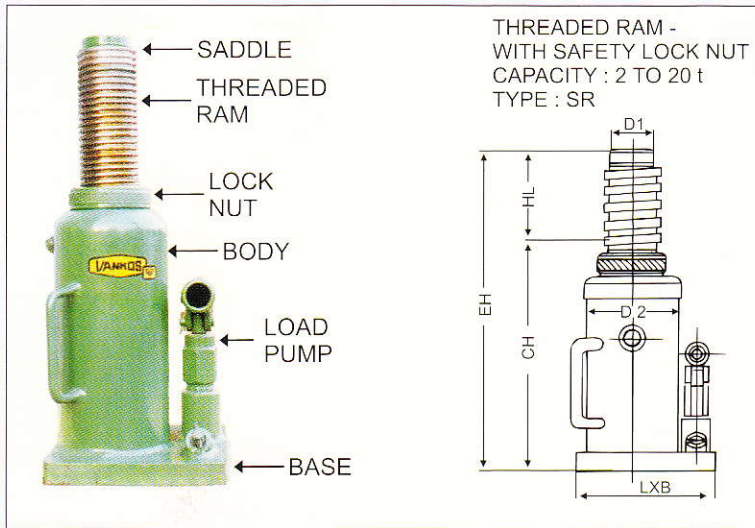

TYPE	SR 2/120	SR 3/150	SR 5/150	SR 8/150	SR 10/150	SR 12/150	SR 15/150	SR 20/150
Capacity In Tonnes	2	3	5	8	10	12	15	20
Closed Ht CH	205	235	248	248	252	252	260	260
Hyd. Lift HL	120	150	150	150	150	150	150	150
Ext. Ht.EH	325	385	398	398	402	402	410	410
Ram Dia D1	30	30	36	43	46	52	58	65
Body Dia D2	65	65	72	86	90	98	110	124
Base Size L x B	115 x 115	115 x 115	125 x 125	150 x 140	150 x 150	150 x 150	170 x 170	180 x 180
Appx. Weight in kg	5	6	8	10	11	12	16.5	22

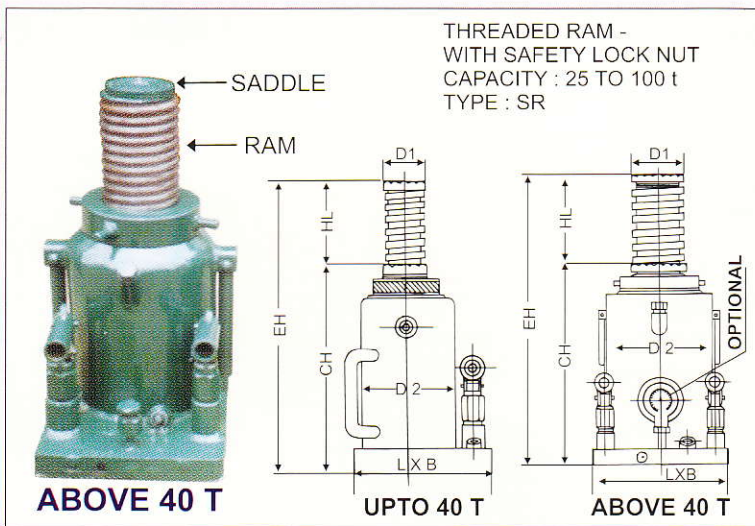

TYPE	SR 25/150	SR 30/150	SR 35/150	SR 40/150	SR 50/150	SR 75/150	SR 100/150
Capacity In Tonnes	25	30	35	40	50	75	100
Closed Ht CH	285	285	300	307	325	325	360
Hyd. Lift HL	150	150	150	150	150	150	150
Ext. Ht.EH	435	435	450	457	475	475	510
Ram Dia D1	70	76	80	90	100	110	127
Body Dia D2	136	144	159	178	198	213	233
Base Size L x B	190 x 190	200 x 200	215 x 200	250 x 225	240 x 300	255 x 315	280 x 330
Appx. Weight in kg	26	32	40	50	70	87	100

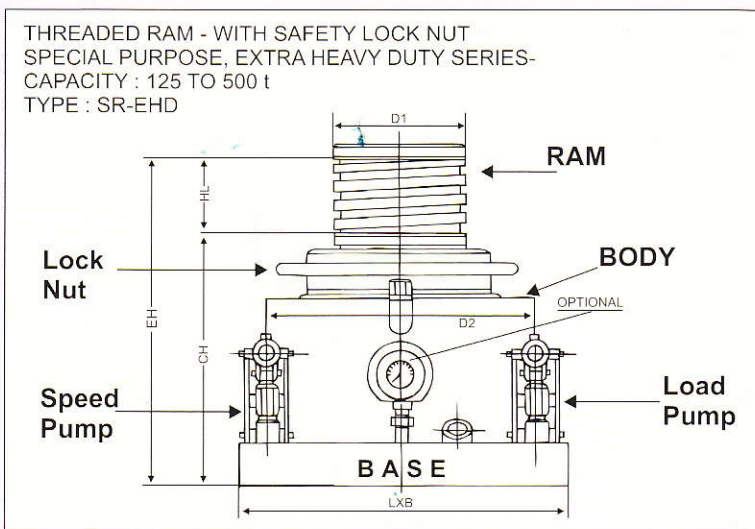

TYPE	SR-EHD 125/150	SR-EHD 150/150	SR-EHD 200/150	SR-EHD 250/150	SR-EHD 300/150	SR-EHD 400/150	SR-EHD 500/150
Capacity In Tonnes	125	150	200	250	300	400	500
Closed Ht CH	360	360	400	400	400	445	500
Hyd. Lift HL	150	150	150	150	150	150	150
Ext. Ht.EH	510	510	550	550	550	595	650
Ram Dia D1	145	155	175	200	210	275	315
Body Dia D2	298	333	358	383	423	523	623
Base Size L x B	380 x 350	420 x 380	450 x 400	500 x 440	520 x 475	675 x 550	820 x 675
Appx. Weight in kg	132	183	255	346	407	649	892

OTHER CAPACITIES AND STROKES CAN BE MANUFACTURED ON VERY SHORT DELIVERY.

Customers to provide the following details to us for their required Hydraulic Jacks :-  
Application, Capacity, Hydraulic Lift/Stroke, Closed Height

RECOMMENDED HYDRAULIC OIL :  
IOC SERVO SYSTEM 32/46/57 OR ITS EQUIVALENT LIKE BHARAT PETROLEUM-HYDROL 32, HPC-ENKLO 32, CASTROL HYSY IN AWS 32/46, CHEMOLEUMS-ERATO 32 AW, APAR LTD-POWER HYDROL 32

## NEW ROTATING PUMP MODELS :

### (A) ROTATING PUMP MODELS - PLAIN RAM - SINGLE PUMP - EXTENSION SCREW

TYPE	RP-SS-15/150	RP-SS-20/150	RP-SS-25/150	RP-SS-30/150	RP-SS-35/150	RP-SS-40/150
CAPACITY	15	20	25	30	35	40
LIFT, HL	150	150	150	150	150	150
CLOSED HEIGHT, CH	250	250	270	270	280	287
EXTENSION SCREW, E	100	100	100	100	100	100
BASE SIZE, LXB	210 X 170	220 X 180	230 X 190	240 X 200	255 X 200	290 X 225
RAM DIA, D1	58	65	70	76	80	90
BODY DIA, D2	110	124	136	144	159	178

### (A) ROTATING PUMP MODELS - THREADED RAM - SINGLE PUMP

TYPE	RP-SR-15/150	RP-SR-20/150	RP-SR-25/150	RP-SR-30/150	RP-SR-35/150	RP-SR-40/150
CAPACITY	15	20	25	30	35	40
LIFT, HL	150	150	150	150	150	150
CLOSED HEIGHT, CH	260	260	285	285	300	307
EXTENSION SCREW, E	---	---	---	---	---	---
BASE SIZE, L X B	210 X 170	220 X 180	230 X 190	240 X 200	255 X 200	290 X 225
RAM DIA, D1	58	65	70	76	80	90
BODY DIA, D2	110	124	136	144	159	178

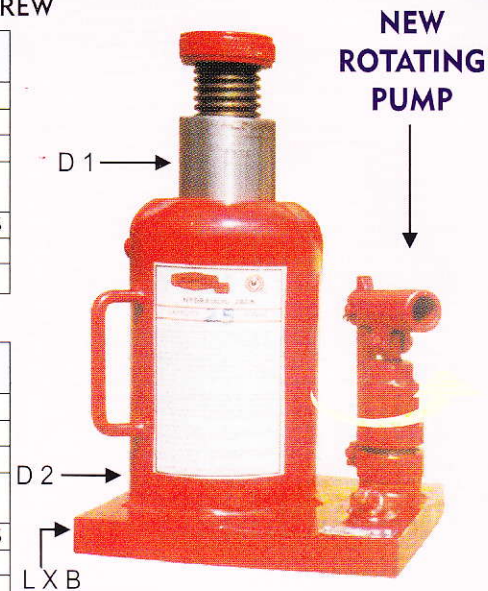

## FOLLOWING TYPE OF TAILOR MADE JACKS ALSO AVAILABLE

TECHNICAL SPECIFICATION  
CAPACITY - 12 TONNES  
HYDRAULIC LIFT - 190MM  
MECH. EXTENSION - 135MM

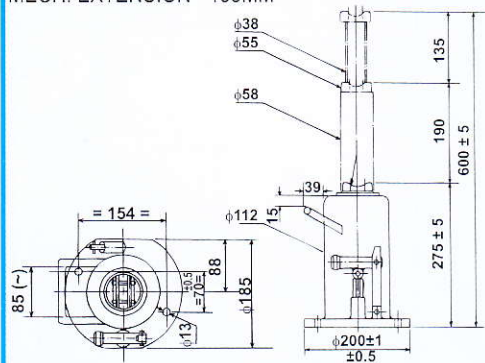

TECHNICAL SPECIFICATION  
CAPACITY - 30 TONNES  
HYDRAULIC LIFT - 200MM  
MECH. EXTN. - 125MM  
SWIVEL SADDLE - 4° to 5°

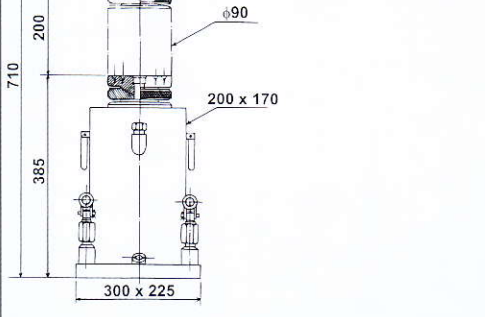

### 3 STAGE TELESCOPIC JACK

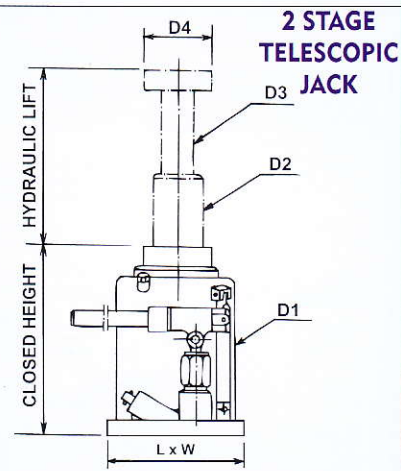
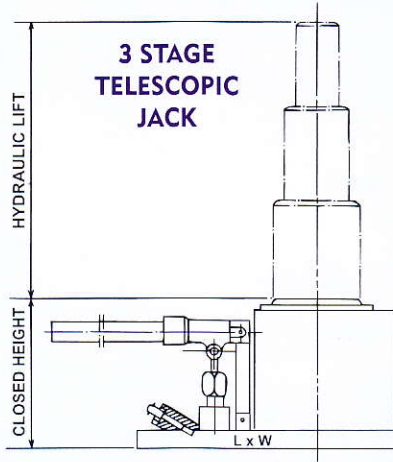
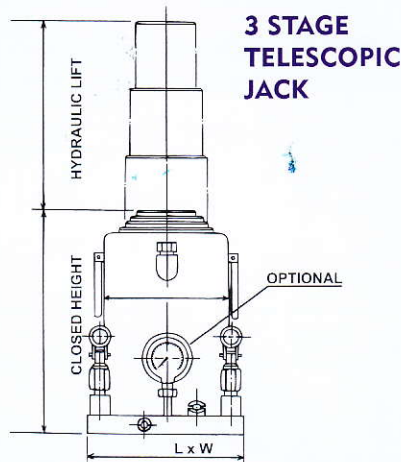
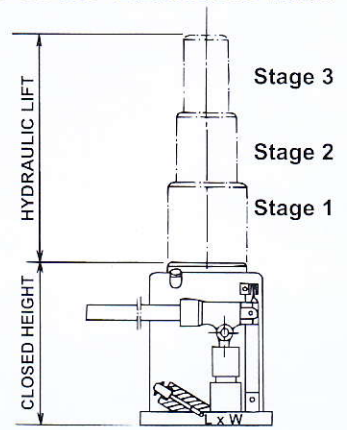

Customers to provide the following details to us for their required Hydraulic Jacks :- Application, Capacity, Hydraulic Lift/Stroke, Closed Height

- All Dimensions are in mm unless otherwise stated.
- Designs and Dimensions are subject to alterations for the sake of improvement without notice
- Copyright of this catalog or any part of it is strictly reserved.

**OTHER PRODUCTS MANUFACTURED BY VANKOS :**

- ★ CYLINDERS/JACKS
- ★ PULLERS
- ★ PRESSES
- ★ PIPE BENDERS
- ★ LIFTING PLATFORMS
- ★ PORTABLE CRANES
- ★ HAND PUMPS
- ★ PALLET TRUCKS
- ★ POWER PACKS
- ★ LOAD CELLS
- ★ NUT SPLITTERS
- ★ GANG JACKING SYSTEMS
- ★ BOLT TENSIONERS
- ★ SMALL TRACK MACHINE
- ★ CRIMPING TOOLS
- ★ HYDRAULIC AIR CRAFT JACKS

AND MANY MORE HYDRAULIC EQUIPMENTS CUSTOM MADE TO ORDER.

### MANUFACTURED BY VANKOS & COMPANY

13/2, INDUSTRIAL ESTATE, PATNA-800013 (INDIA)  
PH. : 2262693, 2262455, 2262838, FAX : (0612) 2262902  
E-mail : support@vankos.com & marketing@vankos.com

**Delhi Office :** Vardhaman City-2 Plaza, 309, Commercial Centre Asaf Ali Road, NEW DELHI-110002 (INDIA)  
Ph. : 011-42831977, Fax : 011-42831988 • E-mail : vankosdelhi@vankos.com

**Mumbai Office :** Navjivan Commercial Premises Co-Operative Society Ltd. Building No. 3/706 (L), Lamington Road, Mumbai-400008 (INDIA)  
Ph. : 022-65254201, Fax : 022-65254202 • E-mail : vankosmumbai@vankos.com

WEBSITE : [www.vankos.com](http://www.vankos.com)